

MWP SERIES

Micro Weighing Scale

- High accuracy
- Total 8 Units available (g, ct, lb, oz, GN, ozt, dwt, tl)
- Counting, Weighing, Percentage Function Modes
- Auto blue backlight (80hours continuous use)
- RS-232 serial interface (PC, Printer)
- Wind shield included



MWP SERIES Micro Weighing Scale

FEATURES

- High accuracy
- Total 8 Units available (g, ct, lb, oz, GN, ozt, dwt, tl)
- Counting, Weighing, Percentage Function Modes
- Auto blue backlight (80hours continuous use)
- Built-in rechargeable battery
- RS-232 serial interface (PC, Printer)
- Wind shield included
- Over load alarm function
- Auto power off function
- Auto span calibration & Auto zero tracking

LARGE PLATTER



DIMENSIONS

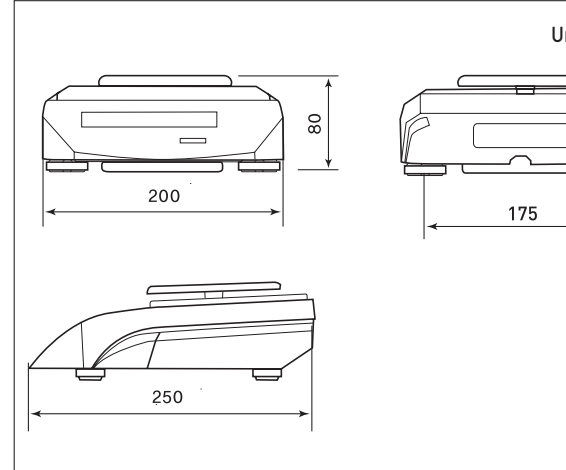

SPECIFICATIONS

Model	MWP-N	MWP-H
Weighing Capacity	150 × 0.005g, 300 × 0.01g, 600 × 0.02g 1500 × 0.05g, 3000 × 0.1g	300 × 0.005g, 600 × 0.01g 1200 × 0.02g, 3000 × 0.05g
Maximum Displayed Resolution	1 / 30,000	1 / 60,000
Application Modes	Weighing, Counting and Percentage (%)	
Display	6 digits LCD (40 × 95mm) with Auto Backlight	
Operating Temperature	0 °C ~ +40 °C	
Power Source	AC Adapter 12V DC/500mA, Internal Rechargeable Lead Acid Battery	
Battery Life	80 Hours Continuous Use with 12 Hours Recharge Time	
Interface	RS-232 or USB Output (Option)	
Platter Size (mm)	150 g~600 g : Ø116, 1200 g~3000 g : 124 × 144	
Dimensions (mm)	200(W) × 250(D) × 80(H)	
Product Weight	1.1 kg (Net)	

OPTION

- USB Interface
- Auxiliary LCD Display



CAS BLDG., # 440-1, SUNGNAE DONG,
GANGDONG GU, SEOUL, KOREA
TEL_ 82 2 2225 3500
FAX_ 82 2 475 4668
<http://www.globalcas.com>

Specifications are subject to change for improvement without prior notice.